



# EUROCOMACH®

MINIDIGGER



## 150.5 SR



Engine YANMAR  
Engine power  
Operating weight

3TNV70-NPR  
Kw 11,2 - Cv 15,2  
Kg 1540



# EUROCOMACH®



**Comfort**



**Maintenance**



**Accessibility**



# MINIDIGGER



## 150.5 SR

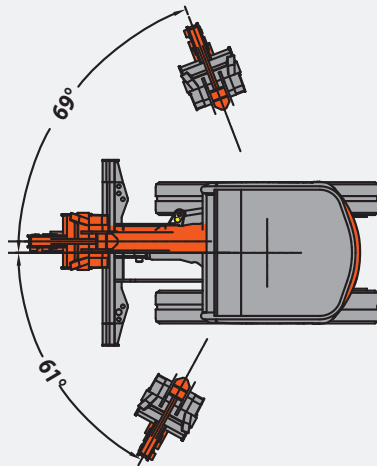
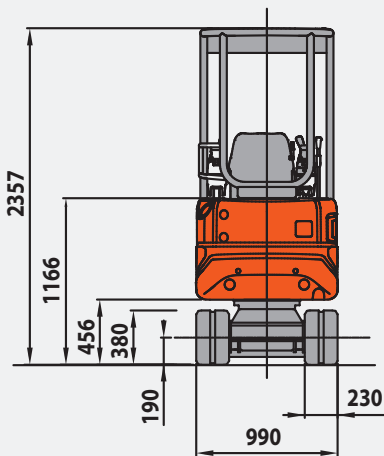
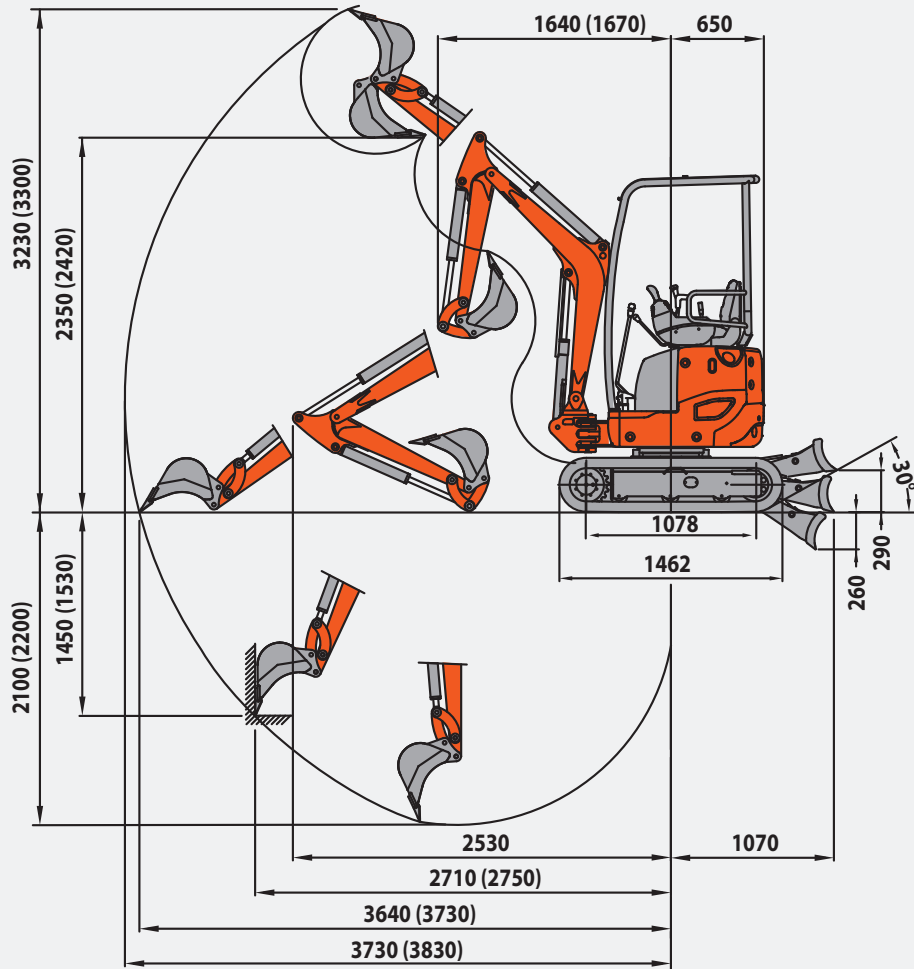

(...) = version with digging arm L = 1100mm

### LIFTING CAPACITY

Opening arm from the rotation's center  
Lifting capacity at 1,0 m height

	1,5	2	2,5	3	max
DOZER FRONT END	540	380	265	165	160
IDLER CENTER	750	460	380	325	280
CRAWLER	400	270	160	120	100

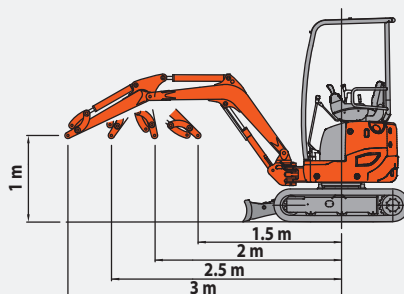

The lifting capacity is based on the ISO 10567 and it does not exceed more than the 75% of static tipping load or more than the 87% of the hydraulic lifting capacity of the machine

## TECHNICAL SPECIFICATIONS

Weight with canopy (rubber tracks)	Kg	1540
Weight with cabin (rubber tracks)	Kg	1650
Travelling speed	km/h	2,2 - 4,2
Slew speed	rpm	12

### ENGINE

Type	YANMAR 3TNV70-NPR	
Power (2260rpm)	Kw 11,2 - Hp 15,2	
Displacement	cc	854
Number of cylinders	n°	3
Cooling	water	
Consumption	Lt/h	2,5
Alternator	V (A)	12 (35)
Battery	V (Ah)	12 (65)

### HYDRAULIC SYSTEM

Pump type	variable flow	
Pump displacement	cc	8+8+6,5
Pump capacity	lt./min	17,6+17,6+14,3
Auxiliary system	lt./min	36
Circuit calibration pressure	Bar	210

### PERFORMANCES

Bucket breaking force (standard arm) ISO 6015	kgf	1550
Arm breaking force (standard arm) ISO 6015	kgf	1150
Traction force	kgf	1500
Ground bearing pressure	kg/cm <sup>2</sup>	0,27
Max slope	60% - 30°	

### DIMENSIONS

Total width	mm	990
Max dumping height with cabin and standard arm (optional arm)	mm	2180 - (2275)
Total height	mm	2357
Rear rotation radius	mm	650
Max digging depth standard arm (optional arm)	mm	2100 - (2200)
Digging arm length std (optional)	mm	950 - (1100)
Tracks width	mm	230
Rollers number (for each side)	3	

### FILLINGS

Fuel tank	lt.	20
Hydraulic oil tank	lt.	20
Hydraulic circuit capacity	lt.	30
Cooling system capacity	lt.	4
Engine oil	lt.	2,8

### CONTROLS

Bucket, boom, swing, slew	2 joisticks
Travel and steering	2 levers / pedals
Dozer blade	lever
Auxiliary hydraulics system	left pedal
Boom swing	right pedal



## STANDARD EQUIPMENTS

- |   |  |
|---|--|
| <ul style="list-style-type: none"><li>• TOPS (EN 13531) - FOPS (ISO 3449) canopy</li><li>• Rubber tracks</li><li>• Landfill blade</li><li>• Translation double speed</li><li>• Digging arm 950 mm</li><li>• Safety belts</li><li>• Air dry filter with electric indicator of clogging</li><li>• Porta documenti</li></ul> | <ul style="list-style-type: none"><li>• Service tool compartement</li><li>• Spare parts catalogue, use and maintenance and tollbox</li><li>• Unipolar electric plug</li><li>• Working light on the first arm</li><li>• Protections on lifting cylinder and blade</li><li>• Two ways auxiliary hydraulic circuit on the digging arm for hammer, drill / tilt bucket</li></ul> |
|---|--|

## OPTIONAL EQUIPMENTS

- |   |   |
|---|---|
| <ul style="list-style-type: none"><li>• Closed cabin TOPS (EN 13531) - FOPS (ISO 3449) with heating system and windscreen wiper</li><li>• Steel tracks</li><li>• Security valves (1<sup>st</sup> arm, 2<sup>nd</sup> arm, bucket)</li><li>• Radio for cabin</li><li>• Working lights and rotating lamp on the cabin</li><li>• Mechanic quick coupling for buckets and fittings</li><li>• Satellite anti-theft device</li><li>• Additional counterweight 80 Kg</li><li>• Digging arm 1150 mm</li></ul> | <ul style="list-style-type: none"><li>• Standard buckets from 250 mm to 600 mm</li><li>• Ditch cleaning buckets from 800 mm up to 1000 mm (fixed or tilting)</li><li>• Trapezoidal bucket</li><li>• Demolition hammer</li><li>• Pinza per tronchi e varie</li><li>• Drill with bits from 150 mm up to 350 mm of diameter</li><li>• Hydraulic arrangement for shredder</li><li>• Shredder 800 mm width</li><li>• Trenchers</li></ul> |
|---|---|



**COMPANY  
WITH QUALITY SYSTEM  
CERTIFIED BY DNV  
=UNI EN ISO 9001:2008=**

**SAMPIERANA s.p.a.**

I - 47026 SAN PIERO IN BAGNO (FC)

Via Leonardo Da Vinci, 40

Tel. +39 0543.904211 - Fax +39 0543.918520

www.sampierana.com - info@sampierana.com

Dealer: